



INSTALLATION INSTRUCTIONS & SPECIFICATION

EVH
160i

PRE – INSTALLATION

NOTE: The preparation of the site, in readiness for the installation of the appliance, is the responsibility of the site owner, not of the manufacturer of the appliance

- a. The floor **must be level** and capable of supporting the weight of the cooker (approximate weight 600kg).
- b. It is important to ensure the flooring is laid before delivery and runs underneath the cooker. Flooring should not be laid up to the cooker after installation.
- c. The cooker measurements are 600mm deep and 900mm high to the working surface with a width of 1598mm.
- d. The cooker is 900mm high to the working surface. If the cooker needs to be raised to match worktop levels, this should be done by way of a plinth built to the appropriate height prior to delivery.
- e. The cooker should be installed with a minimum of 30mm clearance from the back wall to allow for the electric cable entry, and induction hob venting. **This 30mm gap is best sealed by running the worktop behind the cooker, though a standard 30mm stainless infill strip that fits to the back of the cooker is supplied with the Everhot.** On no account should any Everhot model be pushed hard against the back wall as this may damage the electric cable, or block the induction vent. A minimum gap of 5mm per side is required to allow installation and removal of the cooker – please contact us in advance of installation if this is not possible. Where the end grain of a wooden worktop is adjacent to the cooker, we recommend that this is increased to 10mm to minimise the chance of the worktop splitting.
- f. Clearance must be allowed for the raising of the cooker lids into the upright position (minimum height of 1530mm from ground level). Please see side view diagrams for further clarification. A 5mm gap on each side of the cooker lid should be allowed when in the raised position (each lid is 590mm wide to allow for overhead cupboards).
- g. The appliance must be used on 220-240V AC only and should be plugged into three standard, single 13 amp sockets. **Double or multi-gang sockets must not be used.** The 13 amp sockets should be accessible and positioned adjacent to the cooker, so as not to impede the opening of the top lid, and ensuring the plugs are not exposed to steam or excessive moisture. If the sockets cannot be positioned immediately adjacent to the cooker, please see diagrams attached for exact lengths of cables (unfortunately it is not possible to extend these cable lengths). If the power supply cord is damaged, it must be replaced by the manufacturer or their representative, as special purpose tools are required. **An Everhot cooker should NOT be hard wired – please install using the supplied 13amp plugs.**

Your **EVERHOT** cooker has been built to comply with the following UK and European Directives, and carries the UKCA and CE mark.
1. EMC Directive (2014/30/EU) 2. Low Voltage Directive (2014/35/EU)
3. Electromagnetic Compatibility Regulations (2016) 4. Electrical Equipment (Safety) Regulations (2016)

Control of Substances - Health and Safety

This appliance contains the following substances indicated below. It is the User's/Installer's responsibility to ensure that the appropriate precautions are taken when handling, where applicable, any of the materials that could be interpreted as being injurious to health and safety.

Mineral wool, Glass Yarn.

May cause irritation to the skin, eyes, nose and throat, may be harmful if inhaled. Use appropriate protective clothing to avoid contact with body. After handling, wash hands and other exposed parts.

Your cooker does not contain ceramic insulants.

The EVERHOT is a high quality appliance that will provide decades of use, however when you feel that it has reached the end of its working life, please contact us and we will remove it and recycle it free of charge



INSTALLATION INSTRUCTIONS & SPECIFICATION

EVH
160i

The diagrams below are not to scale and are simply to show the relevant dimensions – sockets can be placed either side of the cooker

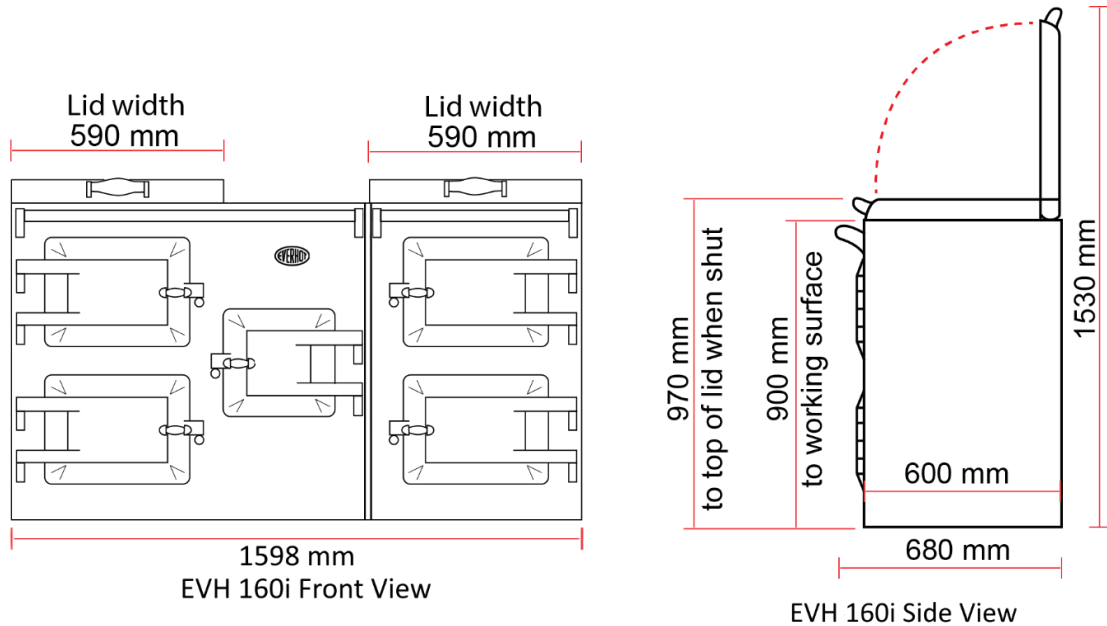

EVH160i dimensions

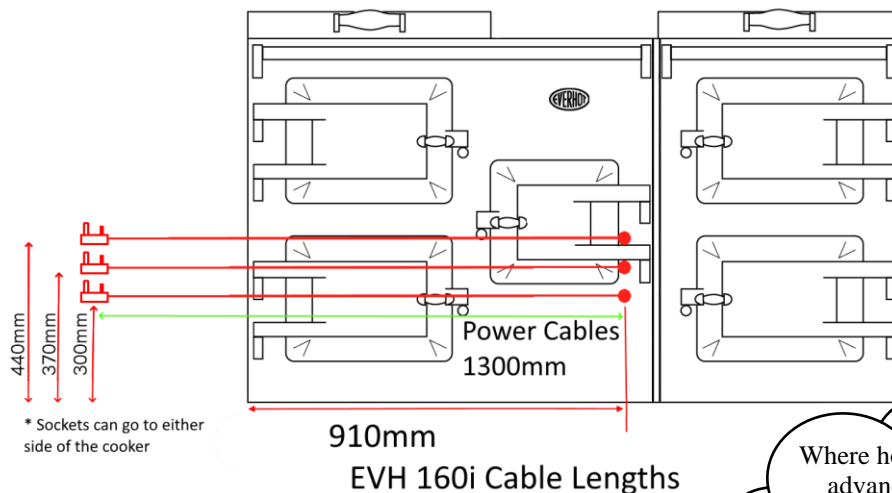

Where holes are prepared in advance for plugs (any model) or controlbox conduit (60 / 120+ only) to pass through, these should be at least 60mm in diameter

POST INSTALLATION

Point a. below will normally be checked by the EVERHOT technician who installs your cooker

- Before use, check that the cooker is level, upright and stable.
- On reaching working temperature, ensure that the hot/simmer plate surfaces are flush with the surrounds - this can be adjusted using a 5mm allen key in the bolts at each corner of the hotplates.
- On initial heating up odours may be given off from the insulants used. These will disappear after a number of hours.